



TFR Burner B-80

Parameter		Specifications
Integral Blower Motor, 60 Hz (HP)		1/2
Maximum Input, BTU/hr (kW) ¹	Integral Blower	477,000 (126)
	External Blower	973,000 (257)
Low Firing Rate, BTU/hr (kW) ¹		50,000 (13)
Pilot Output, BTU/hr (kW) ¹		50,000 (13)
Nominal Operating Gas Pressure at Burner Head, "w.c. (mbar) ² - Natural Gas		4.8 (12)
Nominal Operating Air Pressure at Burner Head, "w.c. (mbar) ²		4.6 (11)
Tube Diameter, inches (mm)		3 (77)
Maximum Tube Length, ft. (m)		30 (9.1)
Piping		NPT
Ignition Type		Pilot
Flame Detection		Flame rod or UV scanner
Fuels		Natural Gas or Propane
Conformance		 

All imperial inputs based on gross calorific values (HHV). All metric inputs based on net calorific values (LHV).

1 Maximum, low fire, and pilot inputs are given for the standard, integral air blowers at 1,000 ft elevation. Higher elevations may require a larger capacity blower.

2 Values are given for integral blower arrangement at high fire.

Test conditions: Natural gas, Max input at 3% excess O₂, Low fire at 19% excess O₂, test fired into effective tube length of 28'.

NOTE: All values are approximate. To check if packages meet other agency requirements, contact the factory. Packages meant for indoor use.

NOTICE: Selas practices a policy of continuous improvement in the design of its products. It reserves the right to change the specifications at any time without prior notice.



The Heat Technology Company™

Data Sheet

Selas TFR Package Burners

Dimensions

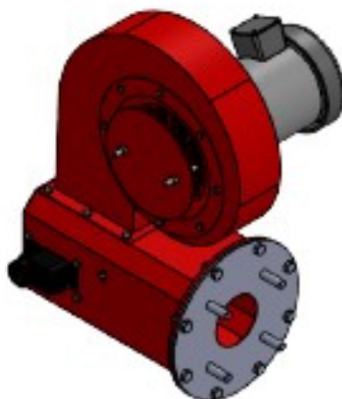

Tube Size	B	C	D	E	G	H	J	K	M	N	P	R	Gas Inlet
3	16-3/4	14-5/8	3-5/32	12-1/4	1	17-1/8	7	4-3/8	10-7/8	4	6	16 mm	1" NPT

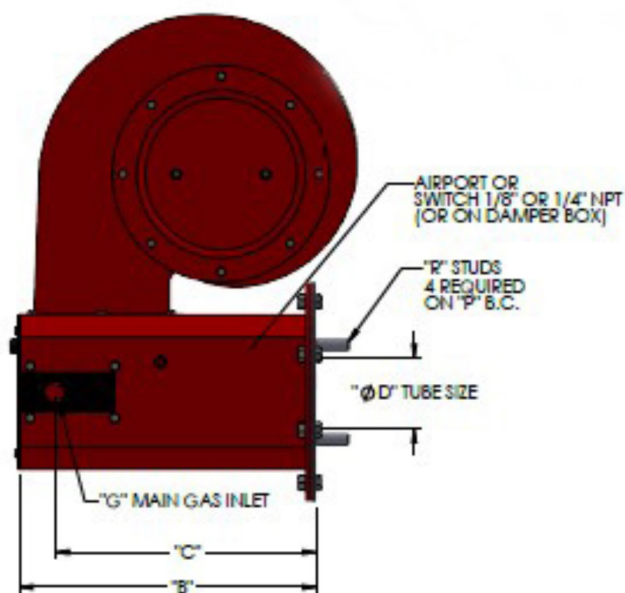
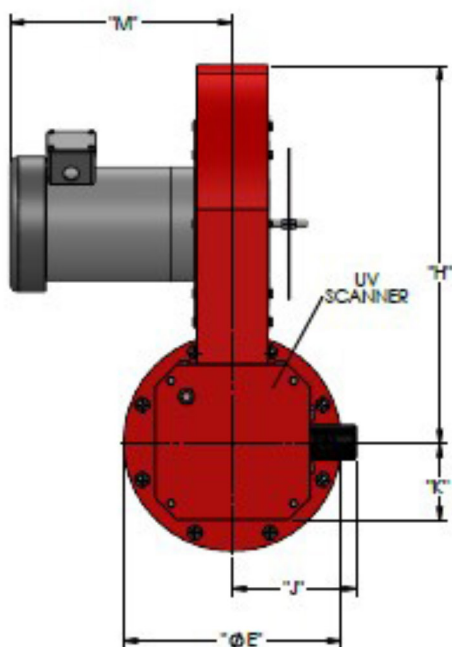

NOTE: All dimensions are in inches $\pm 1/8$. Blower mounted sideways on casing w/motor facing mounting plate when no gas train is required. "M" dimension approximate, dependent on motor manufacturer. Dimensions subject to change without notice. Blower may be mounted in other configurations.



The Heat Technology Company™

Data Sheet

Selas TFR Package Burners

Dimensions (continued)

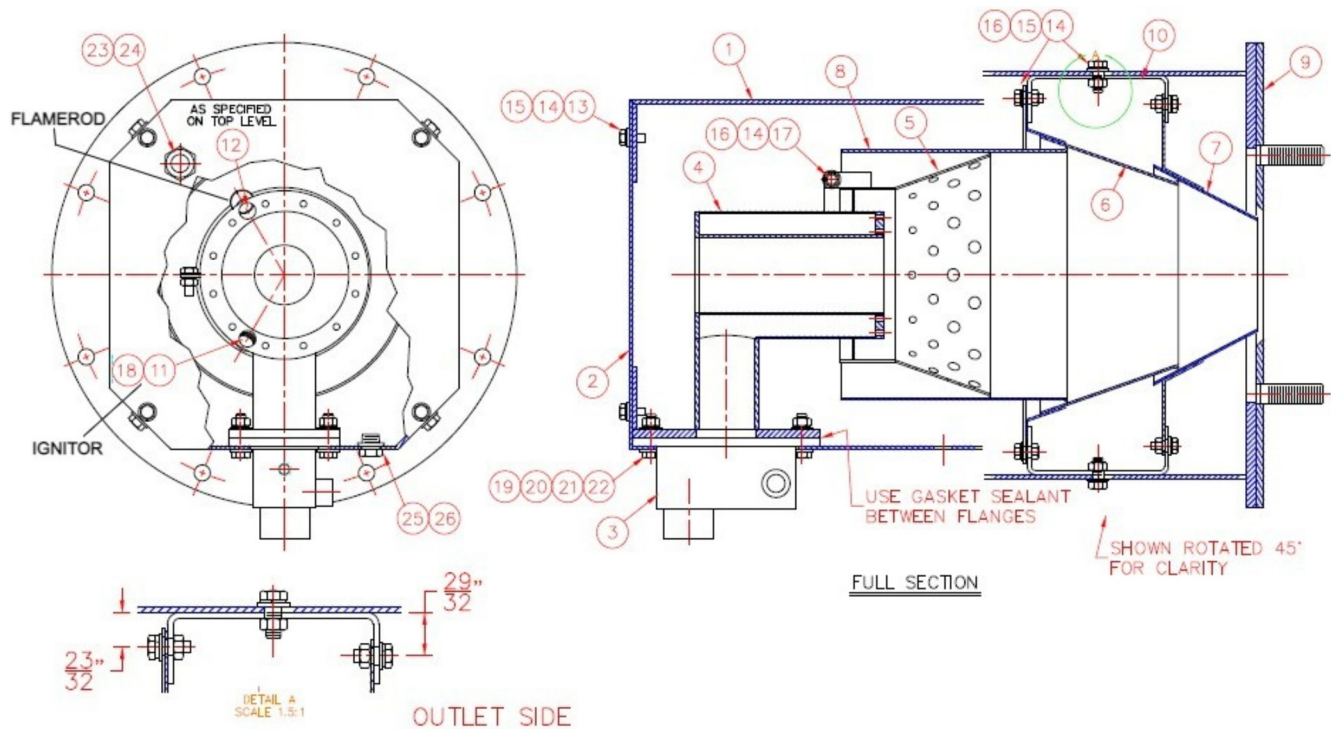

Mounting

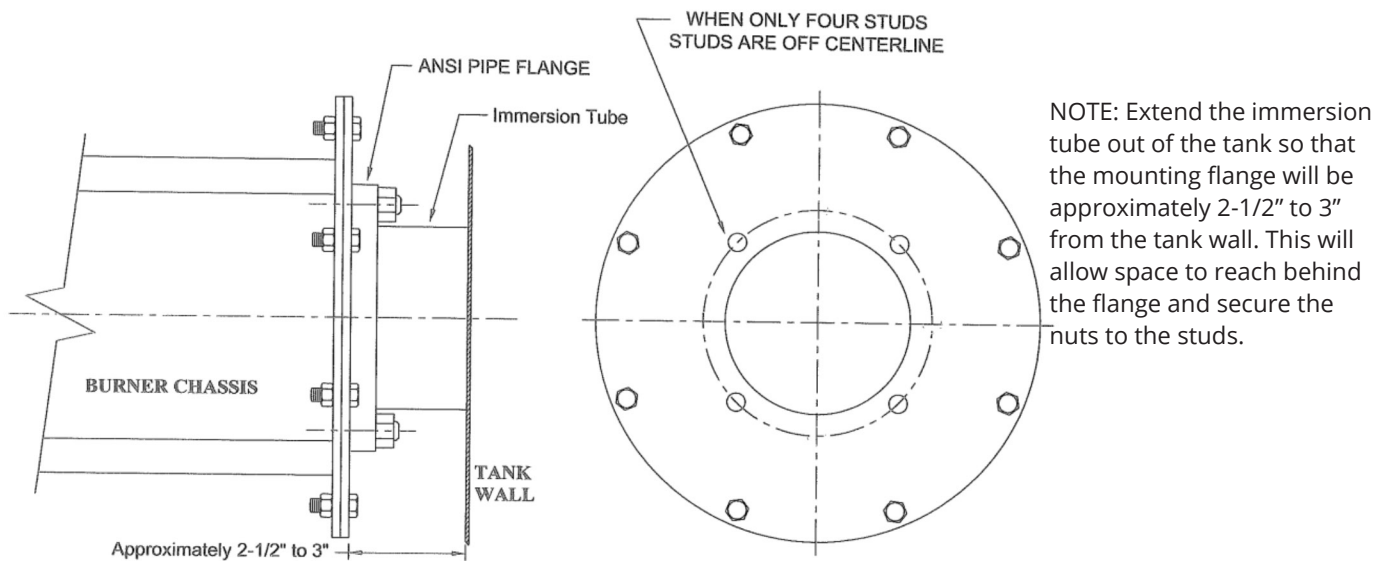

SCAN FOR MORE INFORMATION



The Heat Technology Company™